

IRON ROCK OFF ROAD

WJ 3" ROCK-LINK

1-877-919-JEEP www.ironrockoffroad.com

Lift Kit Instructions

Parts Checklist:

- Logo decal 10001 (Qty: 1)
- Rock-Link Decal 13287 (2)
- Ironrockoffroad.com decal (1)
- 3" Front springs 96004 (2)
- 3" Rear springs 96005 (2)
- Rear sway bar link, 11.25" center to center 92147 (2)
- Front bump stop spacer, 3" 92235 (2)

#2 - Rear Sway Bar Link Hardware (1)

- 3/4" hourglass bushing 94025 (4)
- 12mm sway bar bolt sleeve 92038 (2)
- 10mm sway bar bolt sleeve 92037 (2)
- M10 x 70 sway bar link bolt (2)
- M10 x 1.5 nylock flange nut (2)
- 7/16 USS washer (2)

#3 - Shocks Hardware (1)

- 12mm shock bolt sleeve 404739 (2)
- 7/16" washer (6)
- 5/16 x 1 hex bolt (4)
- 5/16-18 hex nut (4)
- 5/16 washer (8)

#25 - WJ Front 3" Bump Stop Spacer (1)

- M8 x 100 hex bolt (4)
- 1/4" USS flat washer (2)

Front Subframe Box: 13319 (1)

- Subframe center 92270 (1)
- Subframe left outer 92256 (1)
- Subframe right outer 92275 (1)
- T-Case drop spacer 88264 (2)

#183 3-Link Long Arm Subframe Hardware (1)

- Nut Plate 92097 (2)
- M14 x 2.0 x 90 hex bolt class 10.9 (1)
- M14 x 2.0 x 110 hex bolt class 10.9 (2)
- M14 x 2.0 x 120 hex bolt class 10.9 (2)
- 7/16-14 x 1-1/4 hex bolt grade 8 (4)
- M10 x 1.5 x 30 hex bolt class 10.9 (4)
- M10 x 1.5 x 60 hex bolt class 10.9 (4)
- M10 x 1.5 x 80 hex bolt class 10.9 (5)
- M14 x 2.0 nylock flange nut class 10.9 (5)
- M10 x 1.5 nylock flange nut class 10.9 (1)
- 9/16 F436 hardened washer (5)
- 7/16 F436 hardened washer (13)
- 1/4" Rubber trim edging (3")

Front LCA Box: 15783 (1)

- WJ Long LCA Left 85107B (1)
- WJ Long LCA Right 85108B (1)
- Angled Long Arm Male End 91109 (2)

Front UCA Box: 13490 (1)

- WJ 3-Link Front UCA 92277 (1)
- 2 3/8 UCA Male End 91191 (1)

Front Coil Spring Retainer Kit - 80249 (1)

- Front coil spring retainer cone 80061 (2)
- M12 x 35 flange bolt class 10.9 (2)
- 7/16 SAE flat washer (2)
- M12 rivet nut (2)

#6 - Front Brake Line Spacers (1)

- Front brake line spacer 92037 (2)
- M6 x 45 Front brake line bolt (2)
- 1/4" USS washer (2)

#78 - Control Arm Spacer Hardware (1)

- Control arm spacer 90194 (4)

#127 - 2 5/8" 6 Bolt IRO Flex End Hardware (2)

- Inner race 91118 (2)
- Thrust washer 91119 (2)
- 2-5/8" Flex End Ball 91117 (1)
- 10-32 x 1-3/4" Socket Head Cap Screw (6)
- 10-32 Nylock Nut (6)
- 1/4"-28 90° Grease zerk Fitting (1)

#168 - 2-3/8" Flex End Hardware (1)

- End cap 91138 (2)
- Inner race 91139 (2)
- Flex end ball 91140 (1)
- 8-32 x 1-1/2" socket head cap screw (8)
- 1/4"-28 90° grease zerk fitting (1)
- 1/4-28 straight grease zerk (1)

#181 - 3-Link Control Arm Clamping Hardware (1)

- 1/4"-28 x 1-1/8" socket head cap screw (4)
- 3/8-16 x 1 1/4" hex bolt grade 8 (1)
- 1/4"-28 hex nut, grade 8 (4)
- 3/8-16 nylock flange nut (1)
- 3/8 Mil spec washer 95229A480 (1)

#297 - M12 Rivet Nut Install Tool (1)

- M12 x 50 hex bolt, class 10.9 (1)
- M12 hardened washer, class 10.9 (1)
- Serrated hex install spacer, class 10.9 (1)

#313 - Retainer Cone Spacers (1)

- 1/4" washer 88001 (2)
- Double adjustable track bar 92305 (1)
- Double adjustable track bar male end 92297 (1)
- Double adjuster, track bar 91235 (1)



~Standard Front Track Bar~

#253 - WJ Double Adjustable Track Bar Hardware (1)

- Track bar bushing half 80014 (4)
- 12mm track bar bushing sleeve 92035 (2)
- Track bar clamp 92303 (2)
- M12-1.75 x 70 hex bolt (2)
- M12-1.75 hex nut (2)
- 7/16" USS flat washer (4)

~Optional Front Track Bar~

#122 - Track Bar Flex End Hardware - 12mm (2)

- Inner race (plastic) 91113 (2)
- End cap (steel) 91112 (2)
- Ball 91104 - M12 bolt (1)
- #5-40 x 1 1/4" Socket head cap screw (9)
- 3/32" Hex L key, high torque (hex plus) (1)

#305 - WJ Premium Track Bar Hardware (1)

- Track bar clamp 92303 (2)
- M12-1.75 x 70 hex bolt (2)
- M12-1.75 hex nut (2)
- 7/16" USS flat washer (4)

Shocks

Trail Tamer HD Hydro (Standard)

- Front Shock 79001 (2)
- Rear Shock 79004 (2)

Doetsch Upgrade (Optional)

- Front shock DT 8350 (2)
- Rear shock DT 8299 (2)

#9 – Shock Hardware (1)

- Front Shock barpin 403827 (2)

Bilstein Upgrade (Optional)

- Front shock 33-230337 (2)
- Rear shock 33-186542 (2)

#9 – Shock Hardware (1)

- Front Shock barpin 403827 (2)

Standard Front Sway Bar Links

- Front sway bar link 10.75" center to center 92146 (2)

#4 - Front Sway Bar Link Hardware – 10046 (1)

- 3/4" hourglass bushing 94025 (4)
- 12mm sway bar bolt sleeve 92038 (4)

Optional Front Sway Bar Disconnect Upgrade

- Front sway bar link 10.75" center to center 92146 (2)

#268 – Sway Bar Disconnect Bushings (1)

- Poly Bushing 94025 (4)

#267 – WJ Sway Bar Disconnect Hardware (1)

- Disconnect Pin 94028 (2)
- Spacer Sleeve 94032 (2)
- 1/2-20 x 2-1/2" Hex Bolt, gr8 (2)
- 1/2 F436 Hard Washer (2)
- 1/4" x 1-1/4" Spring Lynch Pin (2)

#288 – WJ Sway Bar Disconnect Sleeves (1)

- 12mm bushing sleeve 92038 (2)



Optional Rear Lower Control Arm Upgrade:

Rear Rubber Bushing Lower Control Arms 13029 (1)

- Adjustable lower control arm, bushing installed 92347B (2)
- LCA male end, bushing installed, straight 99070B (2)

#65 - Adjustable LCA Clamping Hardware (1)

- 1/4"-28 x 1-1/8" socket head cap screw (4)
- 1/4"-28 hex nut, gr8 (4)

#66 – LCA Spacers Hardware (1)

- Lower control arm bushing spacer 90194 (2)

#78 – LCA Spacers Hardware (1)

- Lower control arm bushing spacer 90194 (4)

~OR~

Rear Flex Joint Lower Control Arms 13028 (1)

- Adjustable lower control arm, bushing installed 92347B (2)
- LCA male end, flex joint, straight 92186 (2)



#127 - 2 5/8" 6 Bolt IRO Flex End Hardware (2)

- Inner race 91118 (2)
- Thrust washer 91119 (2)
- Ball 91117 (1)
- 10-32 x 1-3/4" Socket Head Cap Screw (6)
- 10-32 Nylock Nut (6)
- 90 Degree 1/4"-28 Grease Zerk Fitting (1)

#65 - Adjustable LCA Clamping Hardware (1)

- 1/4"-28 x 1-1/8" socket head cap screw (4)
- 1/4"-28 hex nut, gr8 (4)

#66 – LCA Spacers Hardware (1)

- Lower control arm bushing spacer 90194 (2)

#78 – LCA Spacers Hardware (1)

- Lower control arm bushing spacer 90194 (4)

Optional Rear A-Arm Upgrade:

- WJ adjustable a-arm axle mount bracket 92163 (1)

WJ Rear A-Arm Box (Rubber Bushings): 12556

- Rear adjustable a-arm 92133B (1)
- WJ a-arm male end 92162 (1)

#67 - Adjustable A-Arm Hardware (1)

- 1 1/2-12 jam nut (1)
- M14 x 35 cl10.9 hex bolt (3)
- M14 x 100 cl10.9 hex bolt (1)
- M14 cl10.9 hex nut (1)
- 1/2" USS washer (5)

#127 - 2 5/8" 6 Bolt IRO Flex End (1)

- Inner race 91118 (2)
- Thrust washer 91119 (2)
- Ball 91117 (1)
- 10-32 x 1-3/4" Socket Head Cap Screw (6)
- 10-32 Nylock Nut (6)
- 90 Degree 1/4"-28 Grease Zerk Fitting (1)



~OR~

WJ Rear A-Arm Box (Flex Joints): 12555

- Rear adjustable a-arm 92133 (1)
- WJ a-arm male end 92162 (1)

#67 - Adjustable A-Arm Hardware (1)

- 1 1/2-12 jam nut (1)
- M14 x 35 cl10.9 hex bolt (3)
- M14 x 100 cl10.9 hex bolt (1)
- M14 cl10.9 hex nut (1)
- 1/2" USS washer (5)

#127 - 2 5/8" 6 Bolt IRO Flex End Hardware (1)

- Inner race 91118 (2)
- Thrust washer 91119 (2)
- Ball 91117 (1)
- 10-32 x 1-3/4" Socket Head Cap Screw (6)
- 10-32 Nylock Nut (6)
- 90 Degree 1/4"-28 Grease Zerk Fitting (1)

#176 – WJ A-Arm Chassis Flex Joint Hardware (2)

- Inner race 91160 (2)
- Top End Cap 91158 (1)
- Bottom End Cap 91159 (1)
- Ball 91161 (1)
- 10-32 x 1-1/2" Socket Head Cap Screw (6)
- 90 Degree 1/4"-28 Grease Zerk Fitting (1)



Installation Instructions:

Safety Warning: **Important! Read before installation.******

We recommend this system be installed by a qualified professional. Knowledge of suspension component function is necessary for safe installation and post installation inspections. Be sure to re-torque all suspension components after the first 100 miles of use, and frequently inspect all safety critical suspension components.

Before you begin:

- Read all safety warnings.
- Read and understand installation instructions.
- Check all steering and suspension components for wear and replace as needed.
- Contact Iron Rock Off Road with any questions before, during, or after installation.
- Ensure that all parts are present and in good condition using the included shipping checklist.**
- Be sure you have the following tools and supplies:
 - Floor jack
 - Jack stands
 - Basic hand tools (wrenches, sockets, etc....).
 - Multi-purpose grease.
 - Metal cutting tools such as a 4-1/2" angle grinder with thin metal cutting wheel, and a sandpaper flap wheel for an attractive finish. Possibly a Sawzall with metal cutting blades.
 - Paint and primer (for uniframe - black or your choice of color).
 - High Strength Thread locker such as Lock-Tite Red
 - String level or laser level Slope gauge or angle finder.
 - Hand drill with good quality 7/16" and 5/8" drill bit
 - Anti-seize compound for bolts.



Lower Control Arms

Prepare the parts for Installation:

1. Locate **hardware kit #3** and the rear shocks.
2. Grease and install the 5/8" I.D. shock bushings included with the shocks.
3. Grease and install the four 12mm shock bolt sleeves (two from **hardware kit #3**, two included with the shocks). The rear shocks use 12mm sleeves at the top and bottom.
4. Grease and install barpins into the lower end of the front shocks as shown in **figure 1**.
5. Leave the rest of the hardware in the bag for future use.
6. Locate track bar, track bar male end, double adjuster, and **HK #253**. Install clamps onto the double adjuster.

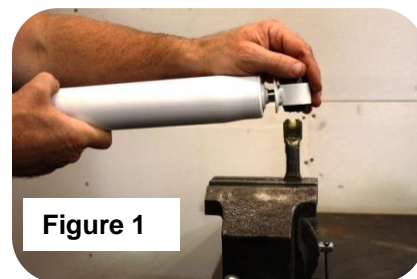

Figure 1

****If you upgraded to the Premium Track Bar refer to the instructions at the end of this document.**

7. Apply anti-seize to all the threads then thread the track bar and male end into the double adjuster. Ensure the ends are equally threaded into the double adjuster then adjust the length to 32-3/4" center to center.
8. Lubricate track bar bushings and steel bushing sleeves with multi-purpose grease and install into track bar.
9. Locate the rear sway bar links (11.25" center to center) and **HK #2**.
10. Grease and install the hourglass bushings.
11. Grease and install the sway bar link bolt sleeves. Each link gets one 12mm I.D. sleeve and one 10mm I.D. sleeve.
12. Leave the rest of the hardware in the bag for future use.
13. If you upgraded to IRO Front Sway Bar Disconnect system, refer to the instructions at the end of this document.
14. **Front Arms:** Locate the lower control arms (larger), male ends (larger, angled), **HK #127** and **HK #181**.
15. Locate the front upper control arm (smaller), male end (smaller, straight), and **HK #168**.
16. Assemble flex ends into lower control arm male ends. Use **HK #127** and attached instructions (2-5/8").
17. Assemble flex end into upper control arm male end. Use **HK #168** and attached instructions (2-3/8").
18. Apply a light coat of anti-seize compound to the threads and thread the male ends into control arms.
19. Adjust upper and lower control arm lengths per the chart as a starting point.
20. Install clamping bolts. Do not tighten at this time.



Threaded Male End

Control Arm Length (Starting Lengths - Center to Center)	
Front Lower Control Arms	36-1/2" (Short Side)
Front Upper Control Arm	33 3/8"
PLUS: Rear LCA	17-7/8"

Control arm mounting subframe:

21. Lift front and rear of vehicle and support with jack stands under the uniframe. Leave room to cut off the stock lower control arm mounts.
 - **Tip: break lug nuts loose before lifting vehicle. ****
22. Raise transfer case **very** slightly and support with a jack stand.
23. Remove the transmission mount bolt and nut from the transmission crossmember.
24. Remove the factory transmission mounting crossmember.
25. Locate the left and right subframe outers and **HK #183**.
26. Add rubber edging to left subframe outer as shown in the picture on the next page.



27. Remove two plastic clips from the fuel lines on the left side of the frame. (arrows)

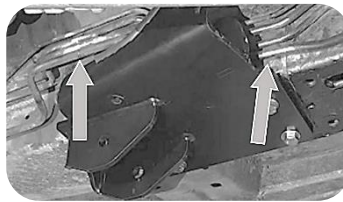

28. Install the new subframe left and right outers using provided M10 x 30 flange and M10 x 80 bolts in the same holes that held the factory crossmember. Be sure that the control arm mounting pockets are facing forward.
29. Tighten bolts firmly (bolts will be removed after drilling.)
30. Drill the additional 7/16" mounting holes, 2 per side at the front of each bracket.
31. Remove subframe outers. Remove any burrs and sharp edges around the holes. Clean, prime and paint any exposed metal.
32. Install nut plates into uniframe and position them over the drilled holes.
33. Install subframe outers using 7/16 x 1 1/4 bolts, M10 x 80 bolts and washers. Leave inside holes open to mount the subframe center section.
34. Install subframe center section using M10 x 30 flange bolts. If using the T-Case drop, align the spacers with the center section mounting holes and use M10 x 60 hex bolts. The notch in the spacer matches the notch in the center section.
35. Torque 7/16 bolts to **65-ft-lbs**. Torque M10 bolts to **34-ft-lbs**.
36. Lower the transfer case on to subframe.
37. Install the factory transmission mounting bolt and nut and torque to **78-ft-lbs**.

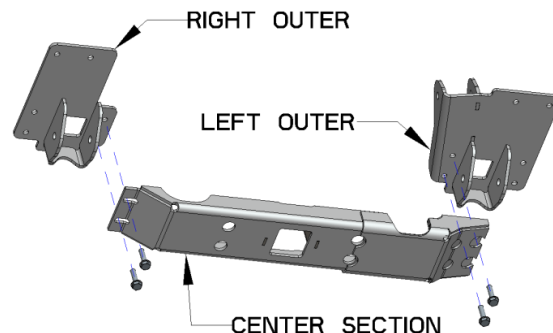

Front Suspension:

38. Remove upper and lower factory control arms, front shocks, springs, front bump stops/ bump stop cups, and disconnect the sway bar links.
39. Disconnect the driveshaft on the axle side and tape the u-joint so the caps do not fall off. Tie the driveshaft out of the way (use tape, zip tie, mechanic's wire, etc.) for easier access to the lower control arm mount.
40. Cut off factory lower control arm mounts from the uniframe on the driver's and passenger's side.
*****Tip: Our favorite tool for this is a 4-1/2" angle grinder with a thin cutting wheel. Remove in pieces for ease of access.*****



41. Clean up any burrs or sharp edges and grind smooth for an attractive appearance.
42. Clean, prime, and paint any exposed metal.
43. Locate **HK #6**. Install front brake line spacers between front brake line and axle where the brake line meets the shock mount. Use new M6 bolts and washers.
44. Locate the coil spring retainers (black cones) and **HK #297**. The coil spring retainers bolt onto the front upper coil spring perch to keep the coil springs from falling out under extreme droop and hold the upper isolator in place.
45. Drill the existing hole in the center of each front upper coil spring perch with a 5/8" drill bit.
46. Using **HK #297** install the M12 rivet nut into the upper coil spring perch.
47. Apply medium strength thread locker (such as Loctite blue) to the threads of both M12 bolts.
48. Position the upper coil spring isolator on the upper spring perch then install the retainer cone with the additional spacer provided **HK #313**. The retainer cone will hold the isolator in place.

49. Torque M12 bolt to **30 ft-lbs**.
50. Install the 3" bump stop spacers with **HK #25** between the original bump stop cups and uniframe
51. Install the upper control arm into the left subframe outer using M14 x 90 hex bolt, 9/16" washer, and M14 flange nut.

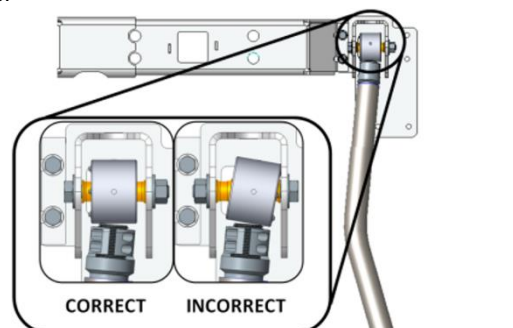

- **Tip: Place M14 nut into an open-end wrench then slide it onto the back side of the subframe outer. Thread the M14 bolt into the nut.**
52. Install upper control arm with the threaded male end at subframe with the bend hanging down to clear the floor of the Jeep.
53. Torque upper control arm bolt on the chassis side to **135-ft-lbs**.
54. Connect the upper control arm to the axle using M10 x 80 bolt with washer and nylock flange nut. Do not tighten at this time.
55. Install lower control arms with threaded adjusting end at the uniframe, and bends facing inward to clear the tires, thread clamping bolts facing down. Use provided M14 x 110 bolts at frame, M14 x 120 at axle, 9/16" washers, and nylock nuts. At the axle, use 2 control arm spacers per side, outboard of control arms.
56. Install track bar. Torque both bolts to **105 ft-lbs**. Do not tighten clamps at this time.

- Note:** The short end of the track bar goes to the axle mount.
57. Install new front springs and new shocks using the factory hardware.
58. Do not tighten the control arm bolts at the axle at this time.



Rear Suspension: (Optional Control Arms & A-Arm see separate instructions)

59. Place a floor jack under the center of rear axle for support (do not lift vehicle).
60. Loosen lower control arm bolts. Loosen nuts but do not remove bolts.
61. Remove factory shocks, springs, and sway bar links. Allow the rear suspension to droop as much as possible.
62. Install new rear springs, sway bar links and new shocks using the factory hardware.
63. Do not tighten the control arm bolts at the axle at this time.

Adjustments and Final Inspection:

64. Raise vehicle and reposition jack stands under the front and rear axles.
65. Temporarily install tire on one side.
66. With full vehicle weight on the suspension, check if the front axle is centered as desired in the wheel opening. Adjust lower control arms to desired front to rear axle position. Adjust front upper control arm to desired castor angle.
67. **Check front caster angle.** Using a laser level or string level, set the front axle level to the rear axle (left side and right). Bounce the Jeep up and down to ensure the suspension is in resting position (at exact ride height). Place the angle finder under the axle "C" (or on top of the upper ball joint). Ensure the angle finder is parallel to the Jeep front to rear. This is your caster angle. See chart for desired setting.
68. Adjust control arms to the desired position.
 - To adjust axle front to rear, adjust upper and lower control arms by the same amount. 12 turns equal one inch.
 - To adjust only caster, adjust only the upper control arm (3 turns equals roughly 2 degrees).
 - To adjust both, adjust both at the same time.

Caster angle may need to be adjusted after a test drive to eliminate driveline vibrations.
69. Check front axle position left to right. Adjust track bar length as needed. Torque the clamps to 60 ft-lbs.
70. With full vehicle weight on the suspension, torque **front** upper control arm nut at the axle to 60 ft-lbs.
71. With full vehicle weight on the suspension, torque front and rear lower control arm bolts to 120 ft-lbs.
72. Torque lower control arm clamping bolts to **140 in-lb.** Be sure to go back and forth between both bolts several times to ensure even clamping.
73. Install tires and wheels. Torque lug nuts (Typical specification is **85-115 ft-lbs.**, depending on your wheels)
74. Recheck all fasteners and torque any remaining loose nuts or bolts to spec.

Front Caster Angle (Starting point)	
Lift Height	Caster
3.0"	6.5 degrees
4.0"	5.5 degrees
5.5"	4.5 degrees
6.5"	3.5 degrees



75. Check all components for clearance for suspension to fully cycle up and down and wheels to turn lock to lock. Pay special attention to brake lines, axle vent hoses, and ABS wires. Reposition as needed by bending the brackets, relocating, or extending hoses and wiring.

*** A professional front end alignment is required after installation. *** Recommended alignment settings:

Caster: +3.5 to +6.5 See chart above.

Toe-in: +1/16" to +1/8"

Final Safety Warning:

* Re-torque all fasteners after 100 miles, and frequently inspect all safety critical suspension components. It is the responsibility of the installer to ensure all fasteners are properly tightened after installation and to ensure the owner knows his/her ongoing responsibility. It is the responsibility of the owner of the vehicle to be sure all safety critical components are inspected frequently, especially after off road or other demanding use.



11. Remove factory shocks, springs, and sway bar links. Allow the rear suspension to droop as much as possible.
12. Disconnect all brake lines and ABS wires from the a-arm.
13. Place a jack stand under the pinion to keep the axle from rotating.
14. Remove the a-arm and a-arm ball joint from the vehicle (no need to separate them)
15. Locate a-arm mounting bracket and **HK #64**. Install the bracket on top of the axle with provided hardware. Use high strength threadlocker and a washer on each bolt. Torque bolts to **100-ft-lbs**.
16. Install the a-arm, with the text facing up (legible from top side), into the factory mounts on the unibody side.
17. Torque the two front M12 bolts to **80-ft-lbs**, and rear flex end mounting bolt to **120-ft-lbs**.
18. Grease flex end grease zerk.
19. Install new rear springs, sway bar links and new shocks using the factory hardware.
20. Attach brake lines, ABS lines, etc... to new A-Arm using cable ties.

Rear Adjustments and Torque:

21. Lower vehicle from jack stands.
22. Measure the rear pinion angle and verify it is the same as the number recorded previously.
23. Adjust the length of the a-arm as needed to achieve desired pinion angle. If a shorter A-Arm length is needed, move the jam nut to the opposite side of the female threads (inside A-Arm instead of outside).
24. Tighten the A-Arm jam nut very tight.
25. With the weight of the vehicle on the springs, torque any loose bolts to spec.
26. Torque all rear lower control arm nuts to **135 ft-lbs**.
27. Tighten control arm jam nuts very tight.
28. Torque any remaining loose bolts to spec.
29. Install tires and place the vehicle on the ground.
30. Torque lug nuts to spec. (**85-115 ft-lbs** depending on your wheels)

Front Adjustments and Final Inspection:

31. Raise vehicle and reposition jack stands under the front and rear axles.
32. Temporarily install tire on one side.
33. With full vehicle weight on the suspension, check if the front axle is centered as desired in the wheel opening. Adjust lower control arms to desired front to rear axle position. Adjust front upper control arm to desired caster angle.
34. **Check front caster angle.** Using a laser level or string level, set the front axle level to the rear axle (left side and right). Bounce the Jeep up and down to ensure the suspension is in resting position (at exact ride height). Place the angle finder under the axle "C" (or on top of the upper ball joint). Ensure the angle finder is parallel to the Jeep front to rear. This is your caster angle. See chart for desired setting.
35. Adjust control arms to the desired position.
 - To adjust axle front to rear, adjust upper and lower control arms by the same amount. 12 turns equal one inch.
 - To adjust only caster, adjust only the upper control arm (3 turns equals roughly 2 degrees).
 - To adjust both, adjust both at the same time.

Front Caster Angle (Starting point)	
Lift Height	Caster
3.0"	6.5 degrees
4.0"	5.5 degrees
5.5"	4.5 degrees
6.5"	3.5 degrees

***Caster angle may need to be adjusted after a test drive to eliminate driveline vibrations. ***

36. Check front axle position left to right. Adjust track bar length as needed. Tighten clamps to **60 ft-lbs**.
37. With full vehicle weight on the suspension, torque **front** upper control arm nut at the axle to **60 ft-lbs**.
38. With full vehicle weight on the suspension, torque front and rear lower control arm bolts to **120 ft-lbs**.
39. Torque lower control arm clamping bolts to **140 in-lb**. Be sure to go back and forth between both bolts several times to ensure even clamping.
40. Install tires and wheels. Torque lug nuts (Typical specification is **85-115 ft-lbs**., depending on your wheels)

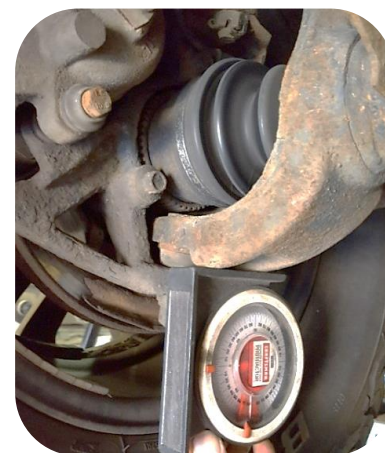

41. Recheck all fasteners and torque any remaining loose nuts or bolts to spec.
42. Check all components for clearance for suspension to fully cycle up and down and wheels to turn lock to lock. Pay special attention to brake lines, axle vent hoses, and ABS wires. Reposition as needed by bending the brackets, relocating, or extending hoses and wiring.

* A professional front end alignment is required after installation. * Recommended alignment settings:

Caster: +3.5 to +6.5 See chart above.

Toe-in: +1/16" to +1/8"

Final Safety Warning:

Re-torque all fasteners after 100 miles, and frequently inspect all safety critical suspension components. It is the responsibility of the installer to ensure all fasteners are properly tightened after installation and to ensure the owner knows his/her ongoing responsibility. It is the responsibility of the owner of the vehicle to be sure all safety critical components are inspected frequently, especially after off road or other demanding use.

IRON ROCK OFF ROAD

2-5/8" IRO Flex End (6 bolt)

1-877-919-JEEP www.ironrockoffroad.com

Assembly Instructions

Fits All Iron Rock Off Road Long Arm Systems, WJ A-Arms, and Build Your Own Flex End Assemblies.

Before you begin:

- o Read and understand installation instructions.
- o Contact Iron Rock Off Road with any questions before, during, or after installation.
- o **Ensure that all parts are present and in good condition per attached shipping checklist!**
- o Have these tools handy:
 - o 5/32" Allen head socket
 - o 3/8" open end wrench
 - o Inch-lb. torque wrench
 - o Multipurpose grease/grease gun

Parts Checklist:

- Outer housing, weld on (may already be attached to your existing control arm)

#127 - 2-5/8" IRO Flex End (6 bolt)

- 2-5/8" flex end race 91118 (2)
- Thrust washer 91119 (2)
- 2-5/8" flex end ball 91117 (1)
- #10-32 nylock nut (7)
- #10-32 x 1-3/4" socket head cap screw (6)
- 90° 1/4"-28 grease zerk fitting (1)

Assembly:

1. Insert two #10-32 socket head cap screws into one thrust washer and one plastic race. Spherical bore of race facing away from thrust washer. (Figure 1)
2. Install this small assembly into the flex end housing. The races are a light press fit, use a wide punch and hammer to assist you if needed.
3. Apply a thin coating of multi-purpose grease to the mating surfaces of the ball and both races.
4. Place the ball in the race (inside the flex end). The ball should perfectly fit the contour of the race. (Figure 2)
5. Insert the other race onto the ball so that the spherical bore is contacting the ball. Once again, the races are a light press fit, use a hammer and wide punch if needed. (The two screws should be through one washer and both races at this point)
6. Insert the second thrust washer on top of the flex end housing, sliding the bolts through the holes. (Figure 3)
7. Start nylock nuts on the two bolts that are in the flex end assembly. Hold the nut and turn the bolt.
8. Insert the remaining four cap screws through the remaining holes and install nuts. (Figure 4)
9. Snug up all of the bolts fairly tight.
10. Torque bolts evenly, starting at one bolt and continuing using a crisscross pattern. Torque all six bolts to **70 in-lbs.**, then to **85 in-lbs.**
11. Install 90° grease zerk fitting so that it is easily accessed in the vehicle.
12. Grease flex end until grease comes out of the races around the ball.
13. Re-torque bolts to **85 in-lbs.** after 5 minutes.



Figure 1

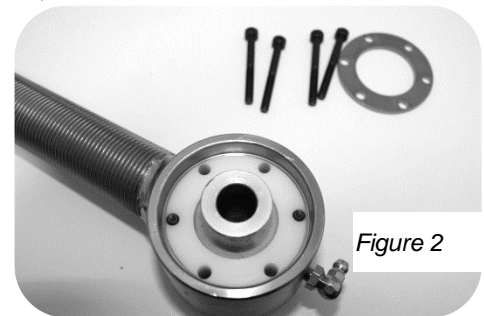

Figure 2



**Reference Only* Complete joint shown fully assembled without housing*

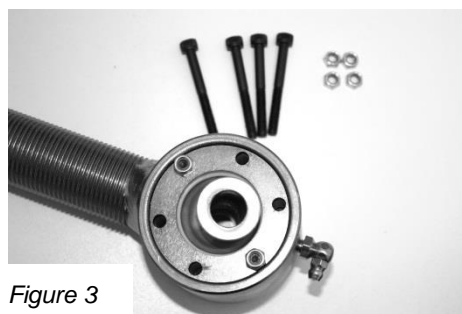

Figure 3

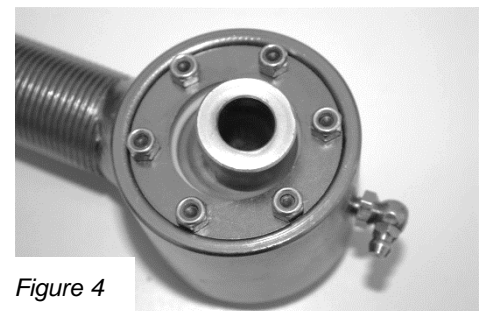

Figure 4

IRON ROCK OFF ROAD

2-3/8" IRO Flex End (8 bolt)
 Assembly Instructions

I-877-919-JEEP www.ironrockoffroad.com

Before you begin:

- o Read and understand installation instructions.
- o Contact Iron Rock Off Road with any questions before, during, or after installation.
- o **Ensure that all parts are present and in good condition per attached shipping checklist!**
- o Have these tools handy:
 - o 9/64" Allen head socket
 - o 3/8" open end wrench
 - o Inch-lb. torque wrench
 - o Multipurpose grease/grease gun

Parts Checklist:

- Outer housing, weld on (may already be attached to your existing control arm)

#168 - 2-3/8" IRO Flex End (8 bolt)

- Inner race 91139 (2)
- Thrust washer 91138 (2)
- Ball 91140 (1)
- #8-32 x 1-1/2" socket head cap screw (8)
- 1/4"-28 90° grease zerk fitting (1)
- 1/4-28 straight grease zerk fitting (1)

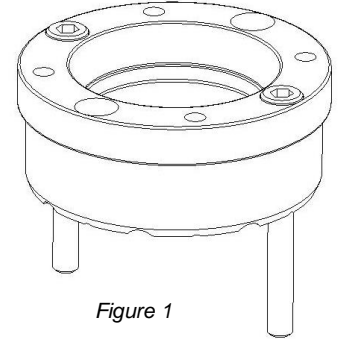
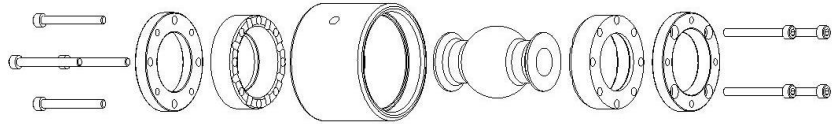
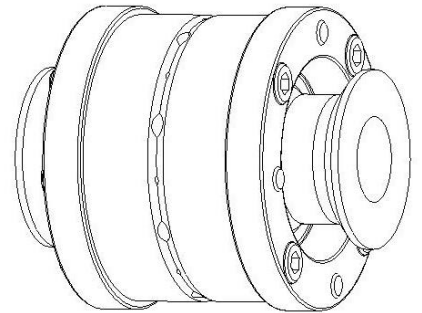

Figure 1

Assembly:

1. Insert two #8-32 socket head cap screws into one thrust washer and one plastic race. Spherical bore of race facing away from thrust washer. (Figure 1)
2. Install this small assembly into the flex end housing. The races are a light press fit, use a wide punch and hammer to assist you if needed.
3. Apply a thin coating of multi-purpose grease to the mating surfaces of the ball and both races.
4. Place the ball in the race (inside the flex end). The ball should perfectly fit the contour of the race.
5. Insert the other race onto the ball so that the spherical bore is contacting the ball. Once again, the races are a light press fit, use a hammer and wide punch if needed. (The two screws should be through one washer and both races at this point)
6. Insert the second thrust washer on top of the flex end housing, aligning the bolts with the threaded holes.
7. Start threading the two bolts into the threaded holes of the thrust washer. Do not fully tighten at this time.
8. Insert the remaining cap screws through the remaining holes and get them started in the threaded washer.
9. Snug up all of the bolts fairly tight. Go back and forth, rechecking each bolt several times to ensure even clamping
10. Torque bolts evenly starting at one bolt using a crisscross pattern, like torquing lug nuts. Torque all eight bolts to **50 in-lbs.**, then to **55 in-lbs.**
11. Install 90° grease zerk fitting so that it is easily accessed in the vehicle.
12. Use a grease gun to grease the flex end through the zerk fitting. This will be difficult due to the tight tolerances in the flex joint assembly.
13. Re-torque bolts to **55 in-lbs.**



**Reference Only* Complete joint shown fully assembled without housing*

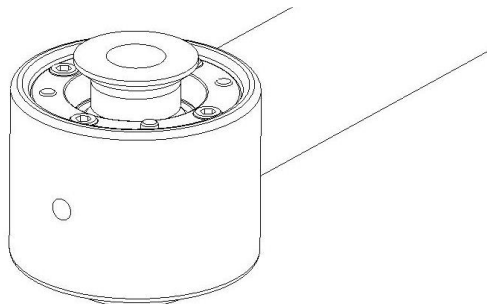

IRON ROCK OFF ROAD

I-877-919-JEEP www.ironrockoffroad.com

Track Bar Flex End Assembly Instructions

Parts Checklist:

#122 - Track Bar Flex End - 12mm (1)

- Inner race (plastic) 91113 (2)
- End cap (steel) 91112 (2)
- Ball 91104 – M12 bolt (1)
- #5-40 x 1 1/4" Socket head cap screw (9)
- 3/32" Hex L key, hi torque (hex plus) (1)

#254 - Track Bar Flex End - 14mm (1)

- Inner race (plastic) 91113 (2)
- End cap (steel) 91112 (2)
- Ball 91142 – M14 bolt (1)
- #5-40 x 1 1/4" Socket head cap screw (9)
- 3/32" Hex L key, hi torque (hex plus) (1)



Safety Warning:

Installation and assembly of this part requires knowledge of steering and suspension systems. Failure to precisely adhere to installation procedure may cause a part failure resulting in vehicle damage and serious injury or death. This part only fits Iron Rock Off Road track bars in good condition. Iron Rock Off Road makes no claims that this part will fit track bars from other manufacturers. Improper fitment may cause a part failure resulting in vehicle damage, serious injury, or death.

Before you begin:

- Read and understand installation instructions.
- Contact Iron Rock Off Road with any questions before, during, or after installation.
- Ensure that all parts are present and in good condition per attached shipping checklist!
- Ensure that you have high strength threadlocker (such as red Loctite) and multi-purpose grease.

Fitment:

This kit replaces the poly bushings and inner sleeve in your Iron Rock Off Road track bar. This part only fits track bars manufactured by Iron Rock Off Road after 2009 with an inside diameter of 1.510", a width of 1.250", and a radiused inside corner.

***To verify fitment: Remove the track bar from your vehicle, remove the poly bushings, clean the parts, and verify the following is true: ***

- The plastic races fit tight inside the inside bore.
- Both end caps fit the inside bore with just a bit of "wobble room".
- Both end caps slide in freely until the flat shoulder rests firmly against the end of the outer tube.
- The overall width of the outer tube is 1.250". This can be measured with a caliper or verified after flex end is fully assembled. Once fully assembled (bolts torqued to spec.) the shoulders of the end caps should rest firmly against the ends of the outer tube. At the same time, the ball should fit tight inside the assembly. It should require a tool (such as a screwdriver) to pivot or rotate the ball. The ball should pivot smoothly with even resistance in any position.



If any of those steps cannot be verified, please contact us to order a new track bar.

Bolt size: This bushing replacement assembly is only available to fit a 12mm & 14mm bolt at this time. Those with a 10mm fastener may wish to upgrade to 12mm hardware for more strength (drill your bracket and install a 12mm bolt).

Assembly:

1. Verify fitment per the "Fitment" section above.
2. Insert four socket head cap screws into one end cap and one race. (Race should have spherical bore facing away from end cap.)
3. Install this small assembly into the track bar outer bushing tube. The races are a light press fit, use a wide punch and hammer to assist you if needed.
4. Apply a thin coat of multi-purpose grease to the ball and the spherical mating surface of the races. Coat both mating surfaces but leave no excess grease that would interfere with the threadlocker adhesive on the bolts.
5. Place the ball into the race inside the housing. The ball should fit the contour of the race perfectly.
6. Insert the other race on top of the ball so that the spherical bore is contacting the ball. Once again, the races are a light press fit, use a hammer and wide punch if needed. (The four screws should be through one end cap and both races at this point.)
7. Apply a generous coating of high strength threadlocker (such as red Loctite) to all 8 screws (including the ones already installed).
8. Install the second end cap, aligning the screws with the tapped holes. When completed 4 screws will be inserted from each side.
9. Insert the last four screws and tighten them all snug.
10. Torque screws in sequence using a crisscross pattern, like torquing lug nuts. Tighten all 8 screws evenly in small steps. Take your time and do not rush. Tighten all 8 screws to **20 in/lbs.**



IRON ROCK OFF ROAD

1-877-919-JEEP www.ironrockoffroad.com

Sway Bar Disconnect
Links Instructions

Parts List:

#268 – Sway Bar Disconnect Bushings (1)

- ❑ Poly Bushing 94025 (4)

WJ ~Optional~

#267 – WJ Sway Bar Disconnect Hardware (1)

- ❑ Disconnect Pin 94028 (2)
- ❑ Spacer Sleeve 94032 (2)
- ❑ 1/2-20 x 2-1/2" Hex Bolt, gr8 (2)
- ❑ 1/2 F436 Hard Washer (2)
- ❑ 1/4" x 1-1/4" Spring Lynch Pin (2)

#288 – WJ Sway Bar Disconnect Sleeves (1)

- ❑ 12mm bushing sleeve 92038 (2)

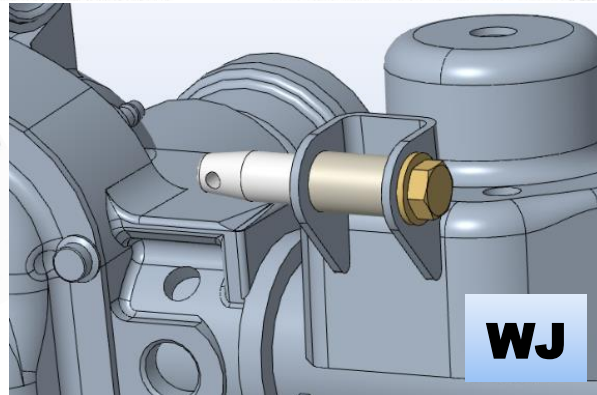

JK ~Optional~

#266 – JK Sway Bar Disconnect Hardware (2)

- ❑ Disconnect Pin 94028 (2)
- ❑ 1/2-20 x 1" Hex Bolt, gr8 (2)
- ❑ 1/2 F436 Hard Washer (2)
- ❑ 1/4" x 1-1/4" Spring Lynch Pin (2)

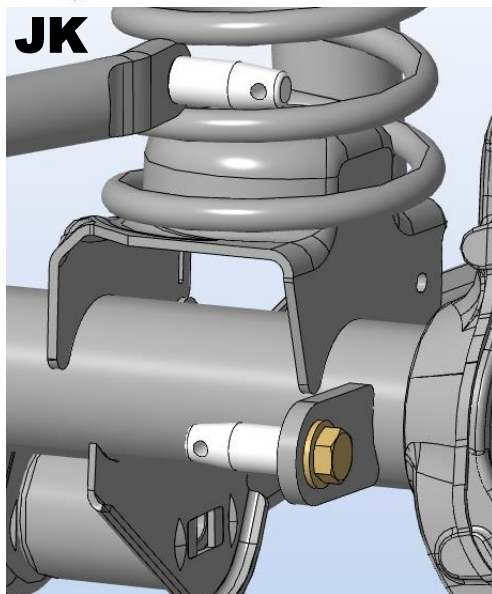

XJ ~Optional~

#287 – XJ Sway Bar Disconnect Hardware (1)

- ❑ Disconnect Pin 94028 (2)
- ❑ 1/2-20 x 1" Hex Bolt, gr8 (2)
- ❑ 1/2 F436 Hard Washer (2)
- ❑ 1/4" x 1-1/4" Spring Lynch Pin (2)
- ❑ 12mm bolt sleeve 92038 (2)
- ❑ M12 x 70 cl10.9 hex bolt (2)
- ❑ M12 cl10.9 hex nut (2)
- ❑ 1/2 x 1 1/2" gr8 hex bolt (2)
- ❑ 1/2 gr8 lock washer (2)
- ❑ 1/2 gr8 hex nut (2)
- ❑ U-Bracket 99000 (2)



TJ & ZJ ~Optional~

#286 – XJ Sway Bar Disconnect Hardware (1)

- ❑ Disconnect Pin 94028 (2)
- ❑ 1/2-20 x 1" Hex Bolt, gr8 (2)
- ❑ 1/2 F436 Hard Washer (2)
- ❑ 1/4" x 1-1/4" Spring Lynch Pin (2)
- ❑ 12mm bolt sleeve 92038 (2)
- ❑ M12 x 60 hex bolt, cl10.9 (2)
- ❑ M12 hex nut, cl10.9 (2)
- ❑ M10 x 30 hex bolt, cl10.9 (2)
- ❑ 3/8" USS washer (2)
- ❑ M10 hex nut, cl10.9 (2)
- ❑ U-Bracket 99000 (2)

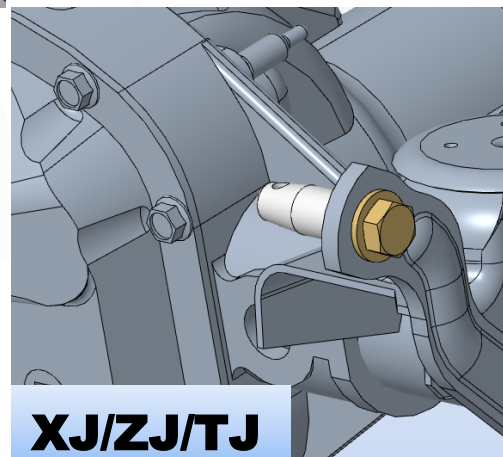

Installation Instructions:

Safety Warning: *Important! Read before installation. *

We recommend this system be installed by a qualified professional. Knowledge of suspension component function is necessary for safe installation and post installation inspections. Be sure to re-torque all suspension components after the first 100 miles of use, and frequently inspect all safety critical suspension components frequently.

Notes:

- ❑ Do not operate vehicle with only one side of the sway bar connected. Both sides of the sway bar must either be disconnected or both sides must be connected.

Before you begin:

- Read all safety warnings.
- Read and understand installation instructions.
- Contact Iron Rock Off Road with any questions before, during, or after installation. 952-210-7185
- Ensure that all parts are present and in good condition using the included shipping checklist.**
- Be sure you have the following tools and supplies:
 - Floor jack and jack stands.
 - Basic hand tools (wrenches, sockets, etc.).
 - Multi-purpose grease

Prepare for installation:

1. Locate the front sway bar links, bushings, and bolt sleeves.
2. Grease and install the hourglass bushings.
3. Grease and install the sway bar link inner sleeves in only one end of each link.
4. Raise the vehicle and secure on jack stands under the frame.
5. Remove the front tires.
6. Disconnect the original front sway bar links from the axle and sway bar.

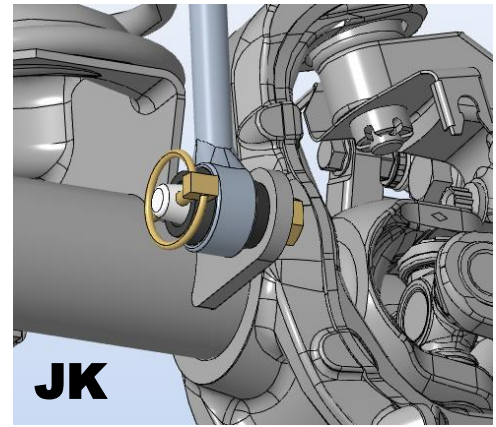

XJ Installation:

7. Locate front sway bar links, two u-brackets, and **HK #287**.
8. Install sway bar link u-brackets to the sway bar using 1/2 x 1-1/2" grade 8 hex bolts, lock washers, and nuts. Brackets mount to the bottom of the sway bar with the bolt facing up and the lock washer and nut on top of the sway bar. Rotate the bracket so it is offset away from the center of the vehicle. Align brackets, torque bolts to **80 ft-lbs**.
9. Install sway bar links driver's side first using provided M12 x 60mm class 10.9 hex bolt and nut through the u-bracket with the nuts toward the outside of the vehicle. Tighten all bolts to **78 ft-lbs**.
10. Install the disconnect pin on the axle, pin pointing in-board. Use the 1/2" x 1" bolt with a washer.
Tip: Before tightening determine your desired orientation for the retaining pin.
11. Hold the disconnect pin in your desired orientation and torque the bolt to **70lb-ft**.
12. Apply grease to the disconnect pin and slide the sway bar link onto the disconnect pin.
13. Secure the sway bar link in place using the spring lynch pin.
***NOTE:** The spring lynch pin should take some effort to install. This is done on purpose to keep the link secure and noise free.
14. Reinstall tires and torque lug nuts to spec.
15. Lower vehicle to the ground.
16. With the vehicle back on the ground, pull the spring pins and slip the sway bar links off the disconnect pins.
17. Swing the sway bar links up to the sway bar then swing the sway bar up to its highest position.
18. Flex the suspension and steer fully left and right. Check for possible interference between the tires and sway bar.
19. Reconnect the sway bar links to the axle.
20. For ease of installation and best performance, re-grease the sway bar bushings periodically.

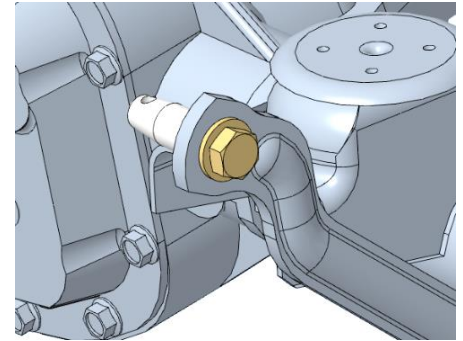

ZJ and TJ Installation:

21. Locate front sway bar links, two u-brackets, and **HK #286**.
22. Install sway bar link u-brackets to the sway bar using M10 x 30 hex bolts nuts and washers. Brackets mount to the bottom of the sway bar with the bolt facing up and the washer and nut on top of the sway bar. Align brackets with offset holes pushing the brackets toward the outside of the vehicle. Torque to **60 ft-lb**.
23. Install sway bar links driver's side first using provided M12 x 60mm class 10.9 hex bolt and nut through the u-bracket with the nuts toward the outside of the vehicle. Tighten all bolts to **78 ft-lb**.
24. Install the disconnect pin on the axle, pin pointing in-board. Use the 1/2" x 1" bolt with a washer.
Tip: Before tightening determine your desired orientation for the retaining pin.
25. Hold the disconnect pin in your desired orientation and torque the bolt to **70lb-ft**.
26. Apply grease to the disconnect pin and slide the sway bar link onto the disconnect pin.
27. Secure the sway bar link in place using the spring lynch pin.
***NOTE:** The spring lynch pin should take some effort to install. This is done on purpose to keep the link secure and noise free.
28. Reinstall tires and torque lug nuts to spec.
29. Lower vehicle to the ground.
30. With the vehicle back on the ground, pull the spring pins and slip the sway bar links off the disconnect pins.
31. Swing the sway bar links up to the sway bar then swing the sway bar up to its highest position.
32. Flex the suspension and steer fully left and right. Check for possible interference between the tires and sway bar.
33. Reconnect the sway bar links to the axle.
34. For ease of installation and best performance, re-grease the sway bar bushings periodically.

WJ Installation:

35. Install the sway bar links onto the sway bar using the original hardware.
36. Install the disconnect pin on the axle, pin pointing in-board, spacer sleeve inside the mount. Use the 1/2" x 2-1/2" bolt with a washer.
Tip: Before tightening determine your desired orientation for the retaining pin.
37. Hold the disconnect pin in your desired orientation and torque the bolt to **70lb-ft**.
38. Install the new bushings into your sway bar links using plenty of multi-purpose grease.
39. Reinstall your sleeves into the top of the sway bar link bushing using multi-purpose grease.
40. Reinstall your sway bar link onto the sway bar and torque the bolts to **70lb-ft**.
41. Apply grease to the disconnect pin and slide the sway bar link onto the disconnect pin.
42. Secure the sway bar link in place using the spring pin.
***NOTE:** The spring pin should take some effort to install. This is done on purpose to keep the link secure and noise free.
43. Reinstall tires and torque lug nuts to spec.
44. Lower vehicle to the ground.
45. With the vehicle back on the ground, pull the spring pins and slip the sway bar links off the disconnect pins.
46. Swing the sway bar links up to the sway bar then swing the sway bar up to its highest position.
47. Flex the suspension and steer fully left and right. Check for possible interference between the tires and sway bar.
48. Reconnect the sway bar links to the axle.
49. For ease of installation and best performance, re-grease the sway bar bushings periodically.

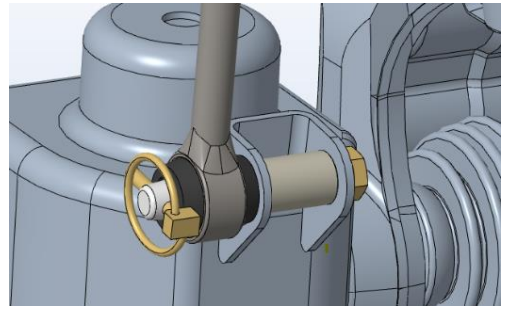

JK Installation:

50. Use a 1/2" drill bit to slightly enlarge the bolt hole in the sway bar. Only a very minor amount of material will be removed.
51. Install the disconnect pin on the axle, pin pointing in-board. Use the 1/2" x 1" bolt with a washer.
52. Install the disconnect pin on the sway bar, pin pointing out-board. Use the 1/2" x 1" bolt with a washer.
Tip: Before tightening determine your desired orientation for the retaining pin.
53. Hold the disconnect pin in your desired orientation and torque the bolts to **70lb-ft**.
54. Install the bushings into the sway bar links using plenty of multi-purpose grease.
55. Apply grease to the disconnect pins and slide the sway bar link onto the disconnect pins.
***NOTE:** Twist the passenger side link onto the lower pin first, then slide it onto the upper pin. It is a snug fit with the factory track bar bracket, but it is achievable.
56. Secure the sway bar link in place using the spring pins.
***NOTE:** The spring pin should take some effort to install. This is done on purpose to keep the link secure and noise free.
57. Reinstall tires and torque lug nuts to spec.
58. Lower vehicle to the ground.
59. With the vehicle back on the ground, pull the spring pins and slip the sway bar links off the disconnect pins.
60. Swing the sway bar up to its highest position.
61. Flex the suspension and steer fully left and right. Check for possible interference between the tires and sway bar.
62. Reconnect the sway bar links to the axle.
63. For ease of installation and best performance, re-grease the sway bar bushings periodically.

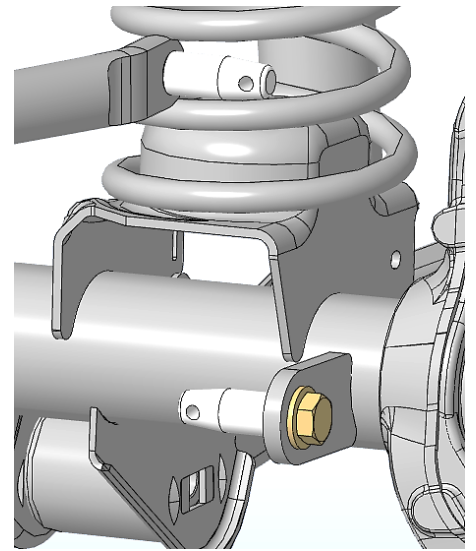

Final Safety Warning:

***Both sides of the sway bar must be disconnected. Do not operate a vehicle with only one side of the sway bar connected.**

Re-torque all fasteners after 100 miles, and frequently inspect all safety critical suspension components. It is the responsibility of the installer to ensure all fasteners are properly tightened after installation and to ensure the owner knows his/her ongoing responsibility. It is the responsibility of the owner of the vehicle to be sure all safety critical components are inspected frequently, especially after off road or other demanding use.

